



Contact US

Website: <https://www.switcgearfactory.com/>

LinkedIn: www.linkedin.com/company/dsj-electrical

Youtube: www.youtube.com/@DSJElectric

Email: info@dsjpowerlink.com

Address: FLC Center, Chaoyang, Beijing, China



-RMU (sf6 free)(4)-

Product Catalog

DSJ Electrical Co.,Ltd





About DSJ

Building Power, Building Trust: **42 Years of Excellence**

Founded in 1983, DSJ has established itself as a leading force in China's electrical distribution industry, with 42 years of expertise in both medium-voltage and low-voltage electrical products.

As an outstanding enterprise, DSJ boasts independent research, development, production, and sales capabilities, ensuring that we can meet customers' needs with the fastest delivery and the highest level of customization. Our workforce consists of over 300 employees, including 50 senior management professionals, 30 experienced engineers, 8 senior designers, and 5 senior technicians.

We specialize in the manufacturing of distribution, circuit protection, and photovoltaic products that exceed both national and international quality standards. Over the past 40 years, DSJ has provided high-quality, safe electrical products to public facilities, large enterprises, and residential sectors worldwide, with one of the lowest return rates in the industry.

As a well-recognized Chinese brand, DSJ is dedicated to upholding our brand integrity. We adhere to the core philosophy of "Quality First, Customer Priority, and Integrity at the Core," striving to bring premium Chinese power equipment and exceptional service capabilities to customers worldwide.

Core Ideology

Quality First

Customer Priority

Integrity at the Core

 **40+**
Years of Excellence

Established in 1983, DSJ has delivered trusted solutions for over four decades, solidifying its position as a pioneer in electrical equipment.

 **15,000+**
Square Meters of Facility

Strong manufacturing capabilities, with the capacity to produce 8,000 units per month.

 **\$108**
Million in Revenue

The continuous growth in sales volume demonstrates the market's recognition of us.

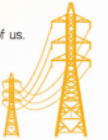

Factory Introduction



DSJ is a financially robust company with a registered capital of **7.84 million USD** and a facility spanning more than **15,000 square meters**.

Our production capabilities are supported by **30 units** of intelligent product testing and debugging equipment, **50 machine tools**, and **6 automated production lines**.

DSJ is also home to four innovation laboratories, holding more than **60 national invention patents**.

Crafting Quality Electrical Products for Over 40 Years



Honors and Certifications

• We are holding more than 60 national invention patents

Invention Patent



Utility Model Patent



• We have been awarded numerous prestigious national-level honors



概述 General Introduction



20 世纪 90 年代以来，随着城市化进程的不断加快以及供电可靠性的不断提高，城市架空线逐步走向埋地电缆，户内开闭所逐步被户外开闭所代替。全绝缘、可触摸、防洪型、体积小、免维护的开关柜快速发展，目前广泛用于城市商业中心、工业集中区、机场、电气化铁路、高速公路等供电可靠性较高的配电系统中，它既可在户内外单独使用，也可集成在预装式变电站之中。

SIRS -12 系列固体绝缘开关柜全面引进先进的生产设备及制造技术，实现本地化生产，大大降低了制造成本，缩短了交货周期，推出后深受用户好评。

Since the 1990s, with the continuous acceleration of urbanization and the continuous improvement of power supply reliability, urban overhead lines have gradually moved toward buried cables, and indoor opening and closing stations have gradually been replaced by outdoor opening and closing. Due to the fully insulated, touchable, flood-proof, small-sized, maintenance-free switchgear rapid development. It is widely used in urban commercial centers, industrial concentration areas, airports, electrified railways, highways and other power distribution systems with high reliability. It can be used indoors or outdoors, or integrated into prefabricated substations.

The products are fully introduced advanced production equipment and manufacturing technology, localize the production, greatly reduce the manufacturing cost, shorten the delivery cycle. It was fully accepted and praised by users after the launch.



产品特点 Product Features

● 功能复合、一体化产品

SIRS 系列开关柜的一次带电部分均密封在环氧树脂浇筑而成的壳体之中，既能避免外界环境因素的影响，又能提高运行可靠性，使其具备免维护（或少维护）的功能，同时还能符合体积小小型化要求。

开关采用三工位（隔离 + 接地）+ 真空灭弧室，该结构是目前技术最成熟的配置方式，特别适合目前电网运行维护需求。

● 完善的机械连锁

SIRS -12 系列开关柜的操作面板具有完善的五防机械连锁功能，所有的连锁功能都在内部已配置好，操作时请按操作说明顺序操作，使用非常方便。

● 灵活的拓展化设计

SIRS 系列开关柜为模块化设计，可以将各种模块通过专用的母线连接件，实现多样化的单元组合，最大限度的满足中国各个地方复杂多样的配电设计方案。

Functional composite, integrated products

The primary live parts of THE SIRS series switchgear are sealed in the shell formed by epoxy resin casting, which can avoid the influence of external environmental factors, improve the operation reliability, make it have the function of maintenance free (or less maintenance), and meet the requirements of volume minification.

The switch adopts three-station (isolation + ground) + vacuum interrupter. This structure is the most mature configuration mode with current technology, and it is especially suitable for the current operation and maintenance requirements of power grid.

Complete mechanical interlock

The operation panel of SIRS -12 series switchgear has perfect five anti-mechanical interlocking function, all interlocking functions have been configured internally, please operate in accordance with the operation instructions in order, it is very convenient to use.

Flexible extension design

The SIRS series switchgear is modular in design, which can combine various modules through special busbar connector, realize diversified unit combination, and satisfy the complex and diverse distribution design scheme in various places to the greatest extent



产品结构 Product Structure

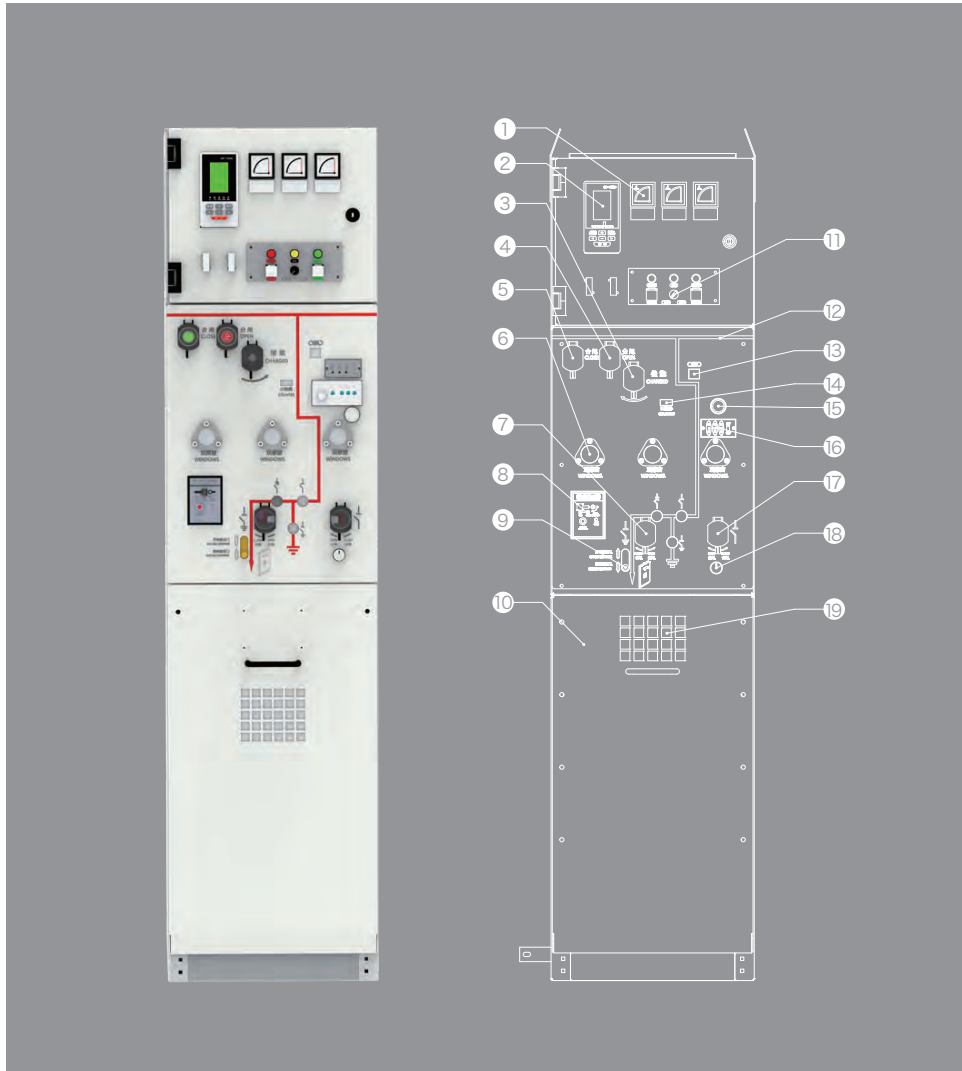

1. 电流表

2. 微机综合保护装置

3. 储能操作孔

利用操作手柄转动储能机构轴，令主开关操作机构储能。不操作时可配置挂锁，防止非授权人员误操作。

4. 主开关分闸按钮

可通过分闸按钮对主开关进行分闸操作。

5. 主开关合闸按钮

可通过合闸按钮对主开关进行合闸操作。

6. 隔离观察窗

通过此观察窗，可以看到接地开关的分闸情况以及隔离开关是处于合闸还是分闸。

7. 接地开关操作孔

利用操作手柄转动接地开关操作轴，可对接地进行分、合闸操作，不操作时可配置挂锁，防止非授权人员误操作。

8. 接地开关电磁锁

防止带电打开电缆室门。

9. 柜门联锁装置

电缆室门与接地开关互锁。当装有互锁机构时，只有在接地开关处于接地合闸、断路器合闸以及柜门联锁拉至解锁位置，电缆室门才可打开，柜门打开后，开关将无法操作。

10. 电缆室门

11. 开关控制器

带保护罩按钮型组合电器单元。集成了储能、合分闸指示、合分闸按钮、就地远方转换开关等功能组成的控制模块。

12. 模拟线路图

指示主开关、隔离开关及接地开关处于合闸还是分闸。

13. 主开关储能指示

观察主开关储能指示可以掌握主开关操作机构的储能情况。

14. 计数器指示

指示主开关操作机构的累积合分闸次数。

15. 隔离照明按钮

通过观察窗照明按钮控制照明灯的开关。

16. 容性带电指示器

带电指示器显示套管是否带电，指示灯下方三个插口可用于二次核相。带电指示器设置开关按钮，有效延长了使用寿命。

17. 隔离开关操作孔

利用操作手柄转动隔离开关操作轴，可对隔离开关进行分、合闸操作，不操作时可配置挂锁，防止非授权人员误操作。

18. 程序锁

保证进线柜与进线柜之间隔离刀无法同时合闸。

19. 电缆室观察窗

1. Ammeter

2. Microcomputer integrated protection device

3. Energy storage operation hole

Use the operating handle to rotate the shaft of the energy storage mechanism, so that the main switch operating mechanism energy storage. The padlock can be configured when not in operation to prevent unauthorized personnel misoperation.

4. Main switch opening button

The main switch can be opened through the opening button.

5. Main switch closing button

The main switch can be closed through the closing button.

6. Isolation observation window

Through this observation window, we can see the opening and closing of the earth switch and whether the isolation switch is on or off.

7. Earthing switch operation hole

Turning the ground switch operating shaft by using the operating handle could open or close the grounding. The padlock can be configured when not in operation to prevent unauthorized personnel from misoperation.

8. Earthing switch electromagnetic lock

Prevent electrification by opening the cable compartment door.

9. Cabinet door interlock device

Cable compartment door and ground switch are interlocked. When equipped with an interlock mechanism, the cable compartment door can only be opened when the ground switch is in the ground closing, circuit breaker closing and the cabinet door interlock is pulled to the unlocking position. After the cabinet door is opened, the switch cannot be operated.

10. Cable compartment door

Button type modular electrical unit with protective cover. Integrating a control module composed of energy storage, closing and opening switch indication, closing and opening button, local remote transfer switch, etc.

12. Analog circuit diagram

Indicates whether the main switch, isolation switch and ground switch are on or off.

13. Main switch energy storage indicator

Observe the main switch energy storage indicator can grasp the main switch operating mechanism energy storage situation.

14. Counter indication

Indicates the cumulative closing and opening times of the main switch operating mechanism.

15. Isolation lighting button

Control the switch of the floodlight through the observation window lighting button.

16. Capacitive potential indicator

A charge indicator indicates whether the casing is live or not. The three sockets below the indicator light can be used for secondary nuclear phase. Switch button is set for live indicator, which effectively prolongs service life.

17. Isolation switch operation hole

Turn the operating shaft of the isolation switch with the operating handle to open and close the isolation switch. Padlock can be configured in case of non-operation to prevent unauthorized personnel from misoperation.

18. The program lock

Ensure that the isolation knives between two or more inlet cabinets cannot close at the same time.

19. Cable room observation window



型号说明 Model Code

注：企业型号定义如下

SIRS-12(CB)/T630-20:
断路器方案

SIRS-12(L)/T630-20:
负荷开关方案

Note: Company named
model code as below

SIRS-12(CB)/T630-20:
Circuit breaker scheme

SIRS-12(L)/T630-20:
Load switch scheme

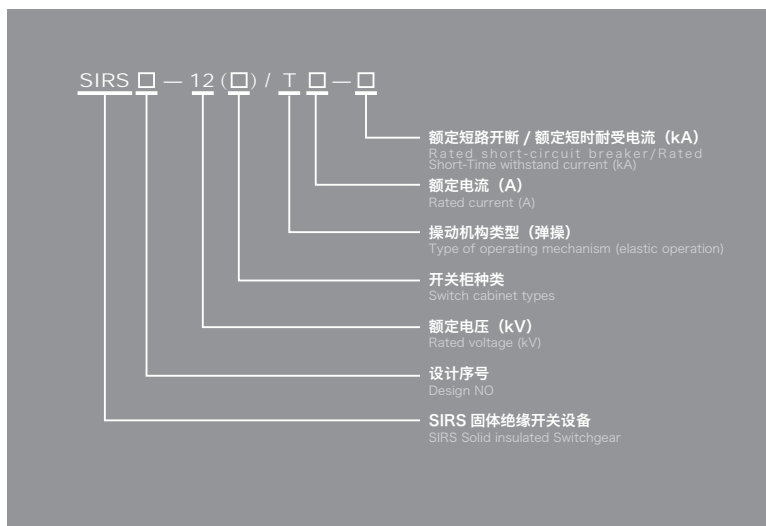

使用环境 Operating Environment

2.4.1 海拔高度：≤2000m（安装海拔高度超过 2000m 请联系兴厦控公司）。

2.4.2 环境温度：最高温度：40℃；最低温度：-40℃；24h 内平均气温不超过 35℃。

2.4.3 环境湿度：24h 相对湿度平均不超过 95%；月相对湿度平均值不超过 90%。

2.4.4 安装环境：周围空气没有爆炸性和腐蚀性气体，安装场所无剧烈振动冲击。

2.4.5 抗震裂度：8 度。

2.4.1 Altitude: ≤2000m (please contact us for installation altitude exceeding 2000m).

2.4.2 Environmental temperature: Maximum temperature: 40°C; Minimum temperature: -40°C;
The average temperature within 24 hours does not exceed 35°C.

2.4.3 Environmental humidity: The average relative humidity within 24 hours shall not exceed 95%;
The average monthly relative humidity does not exceed 90%.

2.4.4 Installation environment: there is no explosive or corrosive gas in the surrounding air, and no violent vibration and impact in the installation site.

2.4.5 Seismic cracking: 8 degrees.



依据标准 Standards

GB/T 11022—2011	高压开关设备和控制设备标准的公用技术要求 Public technical requirements for high voltage switchgear and control equipment standards
GB 3906—2020	3.6kV ~ 40.5kV 交流金属封闭开关设备和控制设备 3.6kV ~ 40.5kV AC metal enclosed switching equipment and control equipment
GB 1984—2014	高压交流断路器 High voltage AC circuit breaker
GB 3804—2004	3.6kV ~ 40.5kV 高压交流负荷开关 3.6kV ~ 40.5kV High voltage AC load switch
GB 16926—2009	高压交流负荷开关—熔断器组合电器 High voltage AC load switch - fuse combination
GB 1985—2014	高压交流隔离开关和接地开关 High voltage AC isolating switch and earthing switch
GB 3309-1989	高压开关设备常温下的机械试验 Mechanical test for high voltage switchgear at normal temperature
DL/T404-2007	3.6kV~40.5kV 交流金属封闭开关设备和控制设备 3.6kV~40.5kV AC metal enclosed switching equipment and control equipment
JB/T 3855—2008	3.6kV ~ 40.5kV 户内交流高压真空断路器 3.6kV ~ 40.5kV Indoor AC high voltage vacuum circuit breaker
GB 4208—2008	外壳防护等级 (IP 代码) Shell Protection Class (IP code)
GB/T 4205—2010	人机界面 (MMI)—操作规则 Man-Machine Interface (MMI) -- Operating rules
GB/T 6388—1986	运输包装收发货标志 Transportation packaging shipping mark
GB 9969—2008	工业产品使用说明总则 General instructions for industrial products
GB/T 13384—2008	机电产品包装通用技术条件 General technical conditions for packaging mechanical and electrical products
GB/T 14436—1993	工业产品保证文件总则 General provisions for industrial product warranty documents
GB/T 191—2008	包装储运图示标志 Packing, storage and transportation pictorial marks

技术参数 Technical Parameters

SIRS -12 系列固体绝缘开关设备主要技术参数表

项目		单位	断路器	负荷开关
额定电压		kV	12	12
额定电流		A	630, 1250	630, 1250
额定频率		Hz	50	50
额定绝缘水平	1min 工频耐压 (相间及相对地)	kV	42	42
	1min 工频耐压 (隔离断口)		48	48
	工频耐压 (控制和辅助回路)		2	2
	雷电冲击耐压 (相间及相对地)		75	75
	雷电冲击耐压 (隔离断口)		85	85
额定短路开断电流		kA	20, 25	—
额定短路关合电流		kA	50, 63	50, 63
额定短时耐受电流		kA	20, 25	20, 25
额定短路持续时间		s	4	4
额定峰值耐受电流		kA	50, 63	50, 63
交流电流 / 转移电流		A	—	—
额定操作顺序		—	O—0.3s—CO—180s—CO	
机械寿命		次	10000	10000
主回路电阻		$\mu\Omega$	≤ 150	≤ 150

以上参数满足国家电网公司、南方电网公司及江苏省电力公司 12kV 开关设备 II 类接地系统技术规范，全面兼容不同的中性点接地方式。

配合 SIRS -12 系列 12kV 电缆附件可实现三路电缆连接组合或两路电缆加一路避雷器连接组合。

备注：I 类：中性点经低电阻接地系统；

II 类：中性点经消弧线圈接地或不接地系统。



Main technical parameters table of SIRS -12 series Solid-insulated switchgear equipment

Item		Unit	Circuit Breaker	Load switch
Rated voltage		kV	12	12
Rated current		A	630, 1250	630, 1250
Rated frequency		Hz	50	50
Rated insulation level	Power frequency voltage withstand/min (phase to phase and phase to ground)	kV	42	42
	Power frequency voltage withstand/min (isolating distance)		48	48
	Power frequency voltage withstand/min (control and auxiliary loop)		2	2
	Lightning impulse withstand voltage (phase to phase and phase to ground)		75	75
	Lightning impulse withstand voltage (isolating distance)		85	85
Rated short circuit breaking current		kA	20, 25	—
Rated short circuit closing current		kA	50, 63	50, 63
Rated short-time withstand current		kA	20, 25	20, 25
Rated duration of short-circuit		s	4	4
Rated peak withstand current		kA	50, 63	50, 63
Take over current/transfer current		A	—	—
Rated order of operation		—	O—0.3s—CO—180s—CO	
Mechanical life		Times	10000	10000
Main circuit resistance		$\mu\Omega$	≤ 150	≤ 150

All the above parameters have met the technical specifications of type II grounding system for 12kV switchgear set by the State Grid, China Southern Power Grid and the Jiangsu Electric Power Company, fully compatible with different neutral point grounding mode.

The combination of three-way cable or two-way cable plus one-way lightning arrester combination can be realized with combination of the SIRS -12 series 12kV cable accessories.

Note: I categories: neutral point by the low resistance grounding system;

II categories: neutral point via arc suppression coil grounded or not grounded system.

基本单元方案 Basic unit solution



基本单元方案简介 Basic unit solution Introduction

3.1 负荷开关单元 C

标准配置与特性:

630A/1250A 母线
真空负荷开关
真空负荷开关手动操作机构
三工位隔离开关
三工位隔离开关手动操作机构
负荷开关和三工位隔离开关位置指示牌
电缆连接套管
显示套管带电的容性电压指示器
柜体
接地母排
操作手柄

可选配置与特性:

真空负荷开关电动操作机构
短路及接地故障指示器
可分离连接器 (电缆接头)
避雷器
进线带电接地闭锁装置
钥匙机械互锁装置
环形电流互感器

3.1 Load Switch Unit-C

Standard configuration and features:

630A/1250A Busbar
Vacuum load switch
Vacuum load switch manual operation mechanism
Three-position disconnector switch
Three station isolation switch manual operation mechanism
Position indicator of load switch and three-station isolation switch
Cable sleeve
Capacitive voltage indicator display bushing charged
Cabinet
Earthing bar
Operation handle

Optional configuration and features:

Vacuum load switch electric operating mechanism
Short and grounded fault indicator
Separable connector (cable connector)
Lightning arrester
Locking device of grounding/charging income line
Key mechanical interlock device
Ring current-transformer

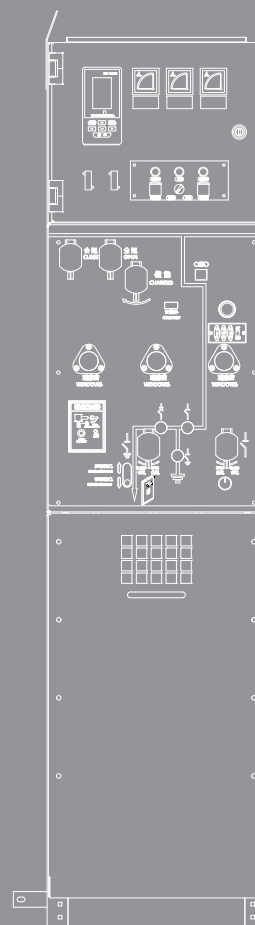

3.2 真空断路器单元 V

标准配置与特性:

630A/1250A 母线
真空开关
真空开关电动操作机构
三工位隔离开关
三工位隔离开关手动操作机构
真空开关和三工位隔离开关位置指示牌
电缆连接套管
显示套管带电的容性电压指示器
挂锁装置
柜体
接地母排
操作手柄
电流互感器 (保护专用)
数字式继电保护装置

可选配置与特性:

短路及接地故障指示器
可分离连接器 (电缆接头)
避雷器
进线带电接地闭锁装置
钥匙机械互锁装置
环形电流互感器及表计

3.2 Vacuum Circuit Breaker Unit-V

Standard configuration and features:

630A/1250A Busbar
Vacuum Switch
Vacuum switch electric operating mechanism
Three-position disconnecter switch
Three station isolation switch manual operation mechanism
Position indicator of vacuum switch and three-station isolation switch
Cable sleeve
Capacitive voltage indicator display bushing charged
Padlock device
Cabinet
Earthing bar
Operating handle
Current transformer (special for protection)
Digital relay protection device

Optional configuration and features:

Short circuit and ground fault indicators
Separable connector (cable connector)
Lightning arrester
Locking device of grounding/charging income line
Key mechanical interlock device
Ring current-transformer and meter

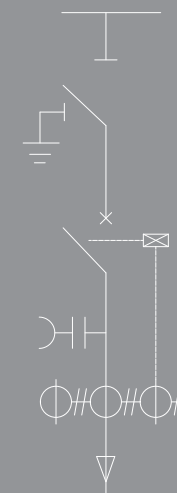
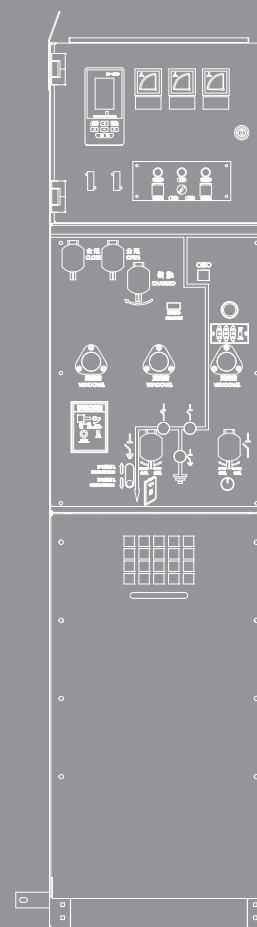

3.3 电压互感器单元 PT

标准配置与特性:

电压互感器
 保护 PT 的熔断器
 1 只带转换开关的电压表
 显示套管带电的容性电压指示器
 柜体

可选配置与特性:

3 只电压互感器
 避雷器

3.3 Voltage Transformer Unit-PT

Standard configuration and features:

Potential transformer
 Fuses that protect PT unit
 One voltmeter with transfer switch
 Capacitive voltage indicator display bushing charged
 Cabinet

Optional configuration and features:

Three voltage transformers
 Lightning arrester

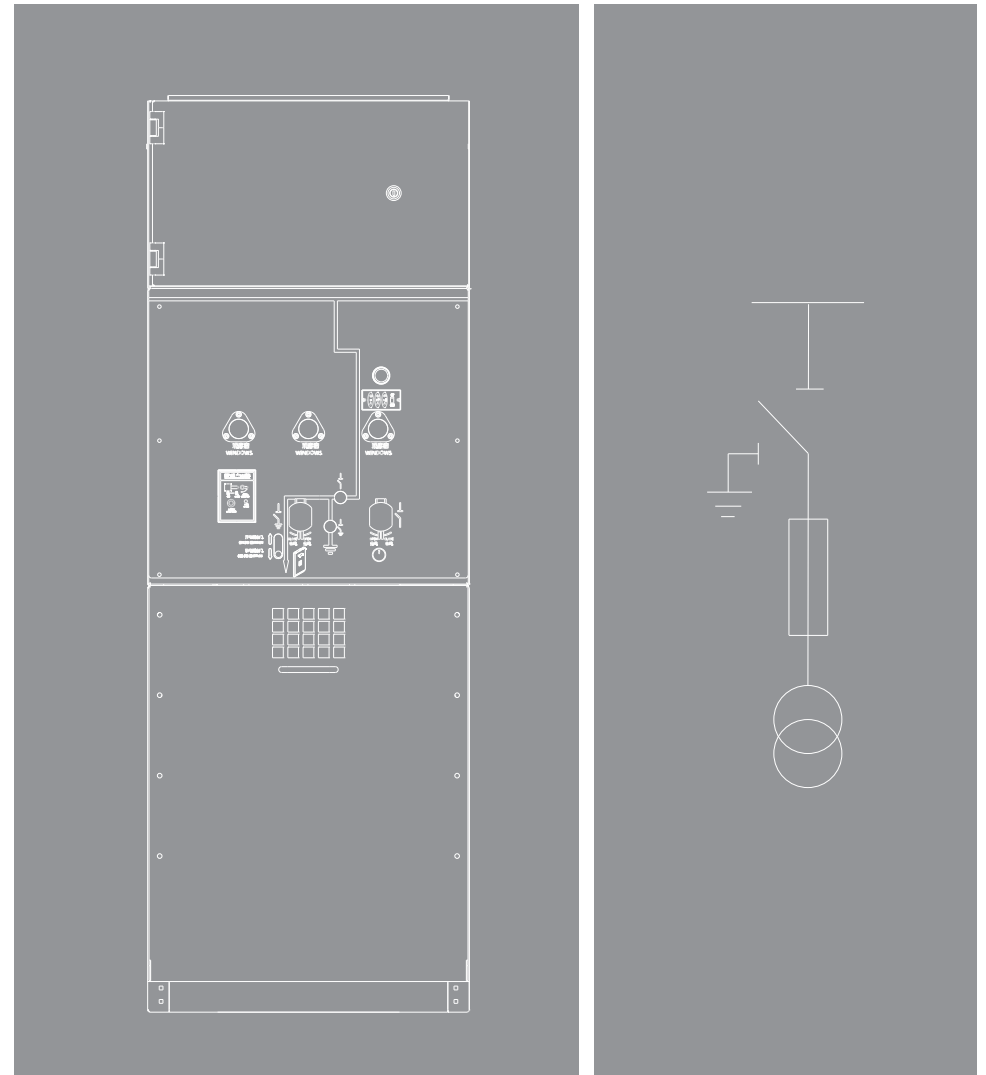

核心元器件技术简介 Technical Introduction of Core Unit



主开关设计 Design of Main Switch

- a、简洁的一次回路设计；
- b、主开关采用真空灭弧技术；

- a、Simple primary loop design.
- b、The main switch adopts vacuum arc extinguishing technology.

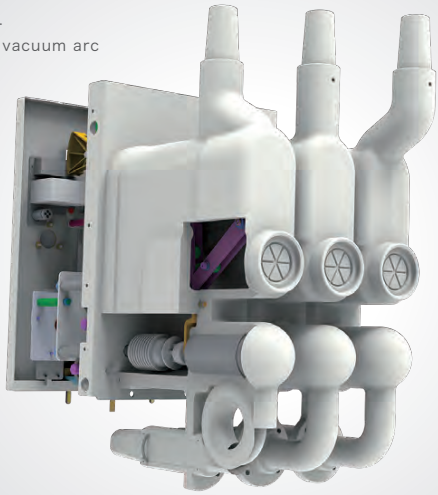

隔离开关设计 Design of Disconnecting Switch

- a、隔离开关采用三工位设计，从理论上彻底避免误操作的发生，隔离刀对接地触头和静触头空气距离 125mm，保证绝缘的可靠性；
- b、高性能的德国慕贝尔碟簧，保证触头压力的稳定性；

- a、The isolation switch adopts three-station design, which theoretically completely avoids the occurrence of misoperation. The air distance between the isolation knife and the ground contact is 125mm, also, the air distance between the isolation knife and the static contact is 125mm, ensuring the reliability of insulation.
- b、High-performance disc spring from Mubea Germany guarantee the stability of contact pressure

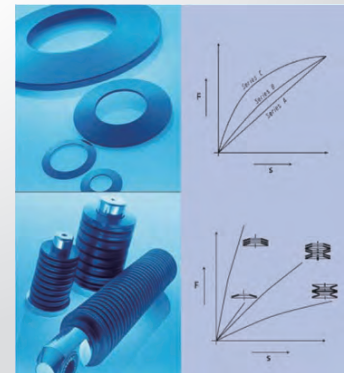



主开关机构设计 Design of Main Switch Mechanism

- a、四连杆机构传动设计，具有重合闸功能；
- b、行星减速直流永磁电动机，体积较小，工作稳定，有着十分惊人的传动效率，能效损失约 3% 左右；
- c、主开关的电动机、辅助开关、脱扣器、行程开关是随时可更换的；
- d、双弹簧精密传动设计，具有重合闸功能；
- e、所有的传动零件采用优质调质钢和淬火钢，使用寿命长；
- f、核心传动采用滚针轴承设计，抗冲击能力强、载荷大、摩擦阻力小；

- a、Four-bar linkage transmission design, with reclosing function;
- b、The planet-decelerated DC permanent magnet motor is small in size, stable in operation, and has an amazing transmission efficiency, with energy efficiency loss of about 3%;
- c、The motor, auxiliary switch, release and travel switch of the main switch mechanism can be replaced at any time.
- d、Double spring precision transmission design, with reclosing function;
- e、All transmission parts shall be made of high quality steel and hardened steel with long lifespan.
- f、The core transmission adopts needle roller bearing design, with strong impact resistance, large load and small friction resistance.

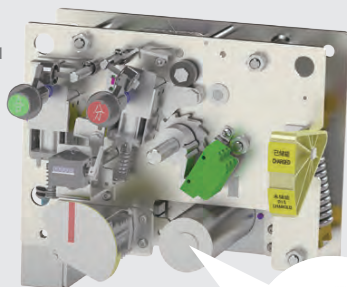

隔离开关机构设计 Design of Disconnecting Switch Mechanism

- a、隔离机构采用扭簧正反转储能方式实现三工位设计；
- b、隔离位置的刚性双向限位设计，防止机构反弹，有效防止操作瞬间断口绝缘击穿；
- c、隔离机构五防连锁刚性连接，可靠防止误操作；

- a、The isolation mechanism adopts the torsional spring positive and negative dump energy mode to realize the three-station design;
- b、The rigid bidirectional limit design at the isolation position prevents the mechanism from bouncing and effectively prevents the breakdown of the broken insulation at the moment of operation;
- c、Five-anti-interlocking rigid connection of the isolation mechanism can reliably prevent misoperation;

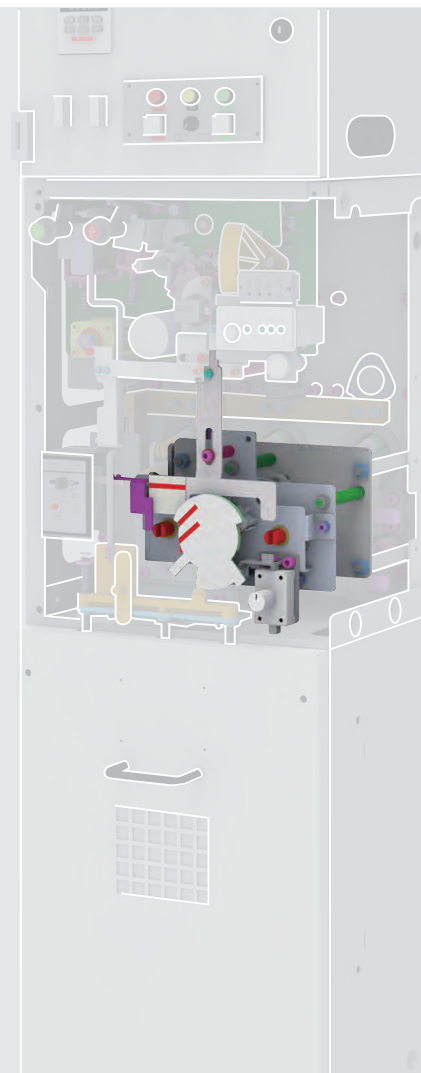
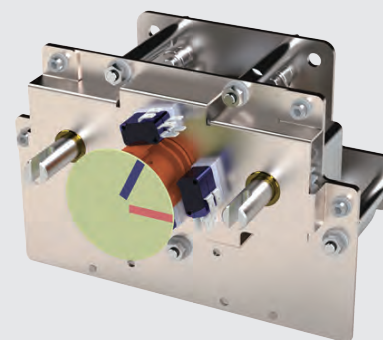



操作面板设计 Design of Operation Panel

- a. 模拟母线清晰明了；
- b. 隔离开关和接地开关分别采用两个独立的操作孔；
- c. 操作孔配有防尘盖，满足 IP4X，可增加挂锁；
- d. 主开关可加装机械程序锁，实现多回路送电的安全操作程序；
- e. 接地开关可加装“电磁闭锁装置”以防止带电误合接地开关；

- a. The simulated bus bar is clear.
- b. Isolation switch and ground switch use two independent operation holes respectively.
- c. The operation hole is equipped with dustproof cover, which can meet IP4X and add padlock.
- d. The main switch can be equipped with mechanical program lock to realize the safe operation procedure of multi-loop power transmission.
- e. The grounding switch can be equipped with "electromagnetic blocking device" to prevent the grounding switch from mistakenly closing on electrification.

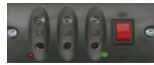

操作按钮设计 Design of Operation Button

- a. 主开关手动操作采用按钮设计，操作简单方便；
- b. 按钮设计有防误操作盖，并可挂锁；

- a. Main switch manual operation adopts button design, simple and convenient operation.
- b. The button is designed with a mis-closing operation cover and can be padlocked.

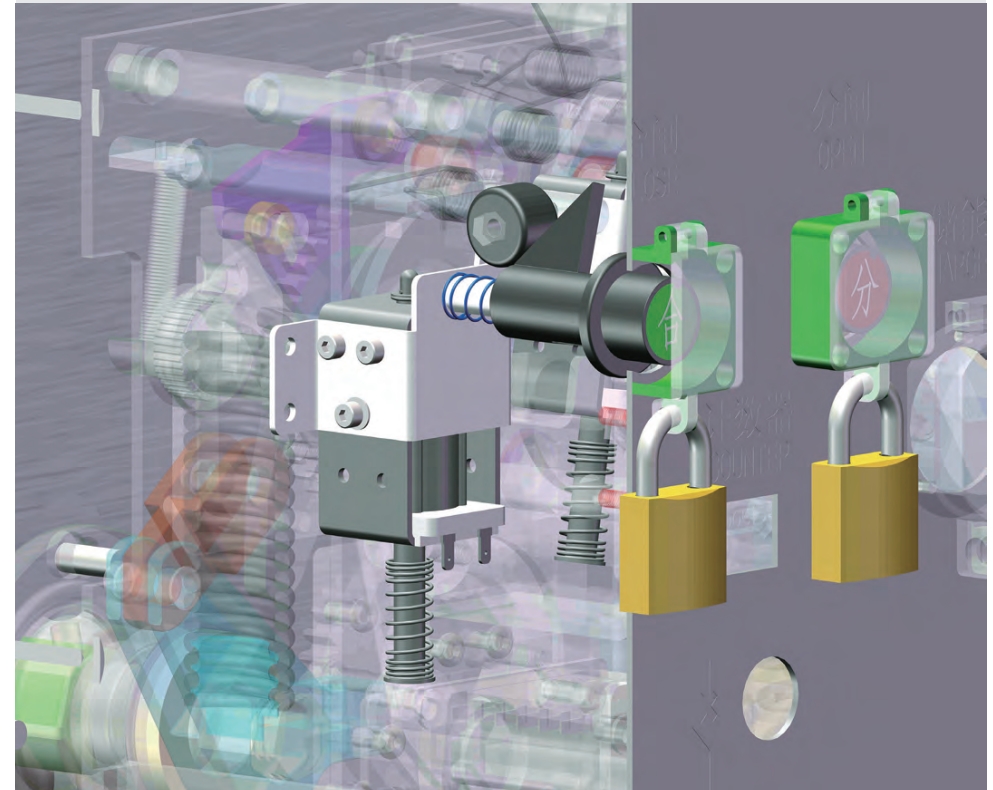

外形及相关尺寸 Appearance and Dimensions



SIRS-12-CVV 外形尺寸
SIRS-12-CVV dimensions

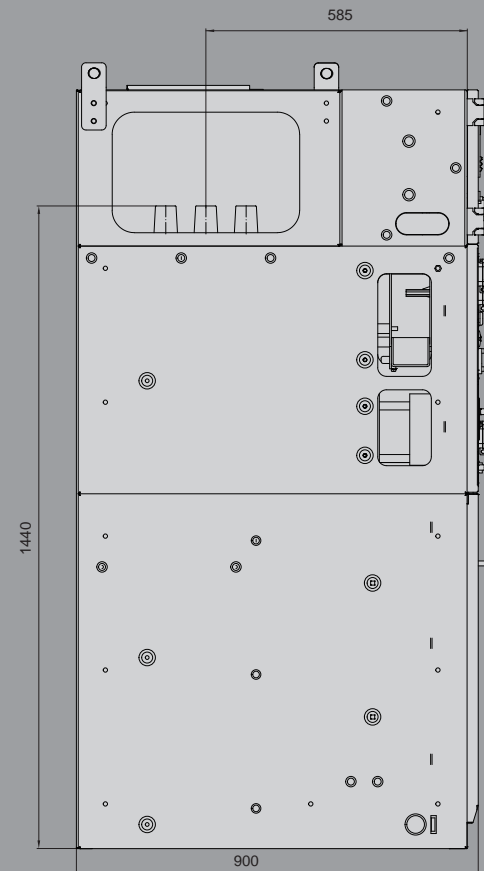
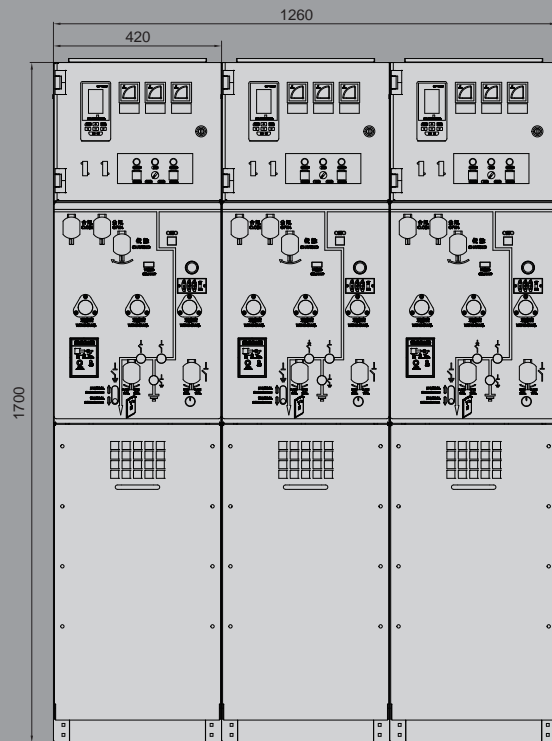

安装相关
About installation

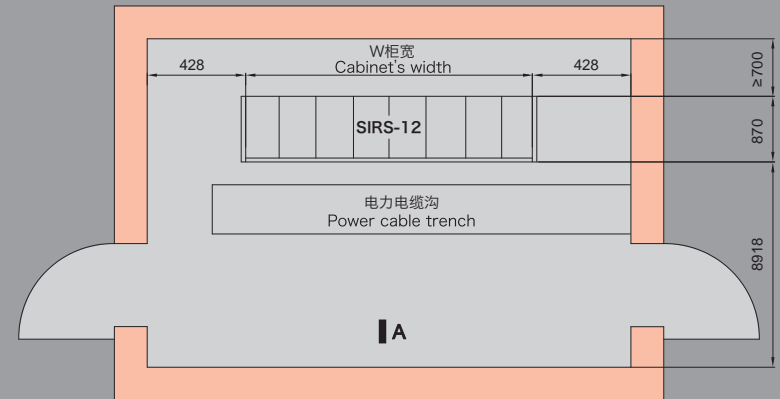
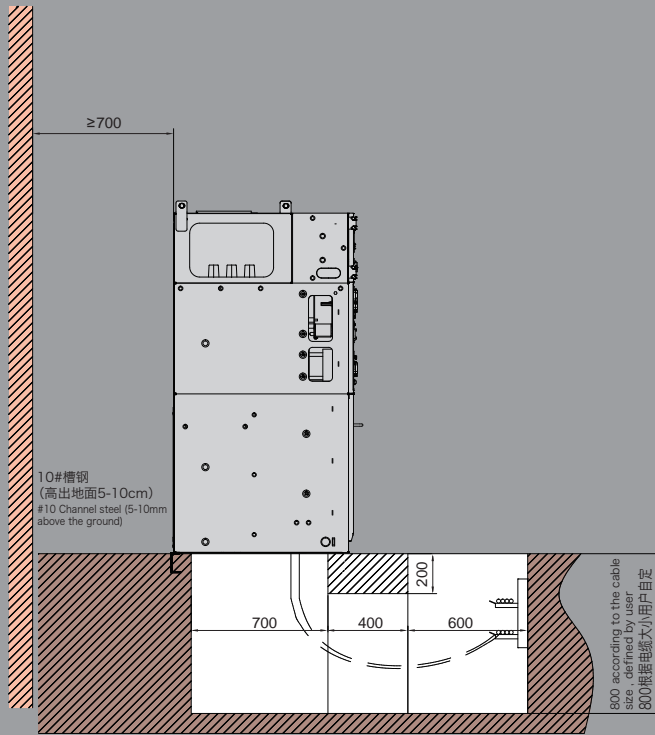

销售网络分布图

Sales distribution network diagram

